

Anschlüsse für Manometerventile

Connections for gauge valves

GM / MM

Zylindrisches Außengewinde

DIN ISO 228/1 mit Zentrierzapfen
gemäß DIN EN837 (DIN 16288)

Parallel male thread

DIN ISO 228/1 with centering
DIN EN837 (DIN 16288)

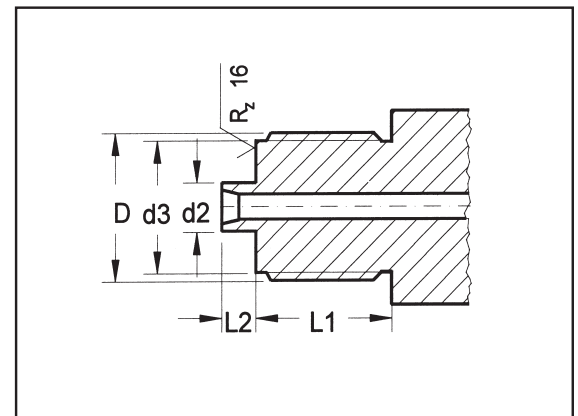

Ventiltyp / type of valve

D	d ₂	d ₃	L ₁	L ₂	Code	M0	M1	M2	A3	A7	A11	E5	S15E
G1/8 B	-	8	10	2	GM 18	●	●	●	●	●	●	●	●
G1/4 B	5,(4)	9,5	13	2	GM 14	●	●	●	●	●	●	●	●
G3/8 B	5,5	13	16	3	GM 38	●	●	●	●	●	●	●	●
G1/2 B	6	17,5	20	3	GM 12	●	●	●	●	●	●	●	●
M20x1,5	6	17,5	20	3	MM 12	●	●	●	●	●	●	●	●

SP

Spannmuffe (Anschlußgewinde links mit Spannmuffe)

Armatur mit zylindrischem Außengewinde DIN ISO 228/1 G-(M-) Links-
gewinde mit Einbohrung und Spannmuffe DIN 16283 zum einstellbaren
Anschluß eines Druckmeßgerätes

Adjusting nut (connection-thread left handed with adjusting nut)

Parallel male thread DIN ISO 228/1 G-(M-)left hand with boring and adjusting nut DIN 16283
for adjustable mounting of pressure gauges

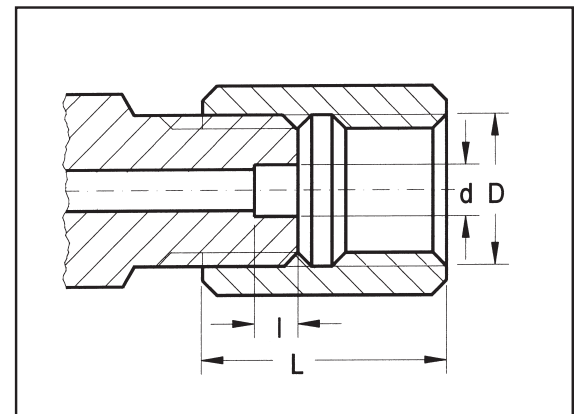

Ventiltyp / type of valve

D	L	d	l _{min}	Code	M0	M1	M2	A3	A7	A11	E5	S15A
G1/4"	23	5,5	3,5	SP 14	●	●	●	●	●	●	●	●
G1/2"	36	7	5,5	SP 12	●	●	●	●	●	●	●	●
M20x1,5	36	7	5,5	SP 20	●	●	●	●	●	●	●	●

Manometerventilanschlüsse gemäß DIN EN 837
Gauge valve connections according to DIN EN 837

Anschlüsse für Manometerventile

Connections for gauge valves

LG / LM

Verschweißter Nippel mit loser Mutter

Zum einstellbaren Anschluß eines Druckmeßgerätes
(Manometer, Druckaufnehmer, etc.)

Nippelverbindung ähnlich DIN EN 837 (DIN 16284)

Union nut

Welded nipple with union nut for adjustable
connection of a gauge

Nipple-connection according to DIN EN 837 (DIN 16284)

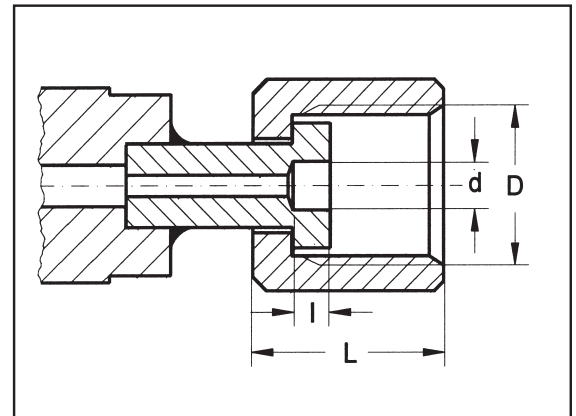

Ventiltyp / type of valve

D	L _{min}	d	l	Code	Ventiltyp / type of valve								
					M0	M1	M2	A3	A7	A11	E5	S15A	
G1/8"	18	4	3	LG 18	●	●	●	●	●	●	●	●	●
G1/4"	22	5,5	3,5	LG 14	●	●	●	●	●	●	●	●	●
G3/8"	25	6	4	LG 38	●	●	●	●	●	●	●	●	●
G1/2" *	30	7	5,5	LG 12	●	●	●	●	●	●	●	●	●
M20x1,5 *	30	7	5,5	LM 20	●	●	●	●	●	●	●	●	●

Weitere Anschlußgewinde auf Anfrage
Other dimensions on request

* G1/2" und M20x1,5
standardmäßig mit Schaft zur
Montage im Meßgerätehalter
DIN 16281 (außer A3)
(s. Kapitel Zubehör Seite Z6)

Auf Wunsch auch ohne diesen
Schaft

* G1/2" and M20x1,5 with shaft for
mounting in a holder DIN 16281
(not for A3)
(s. chapter accessories page Z6)

on request without this shaft

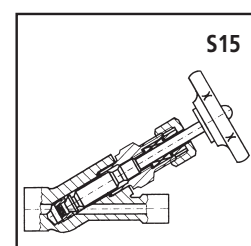
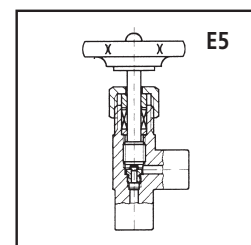
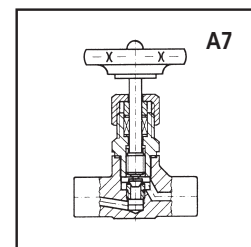
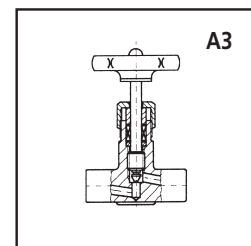
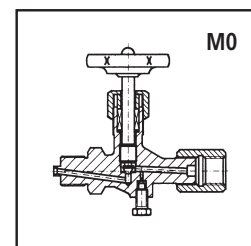
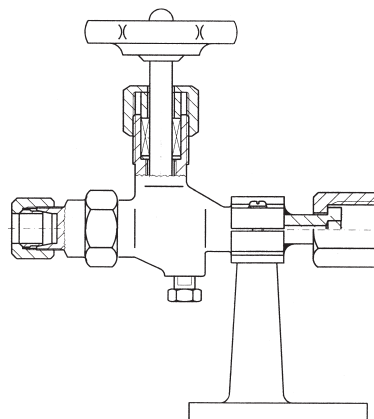
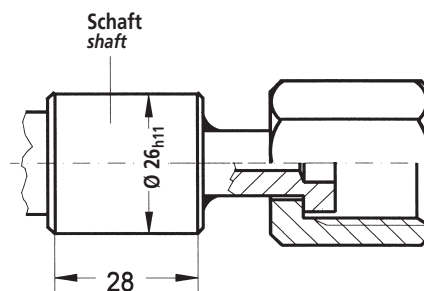

Manometerventilanschlüsse gemäß DIN EN 837
Gauge valve connections according to DIN EN 837

Prüfanschlüsse für Manometerventile

Proof-connections for gauge valves

Code = P1

M20x1,5 Außengewinde mit Verschlusskappe DIN 16287
 Form C (beim Ventil DIN 16271)

M20x1,5 male with cap DIN 16287 form C (for valve DIN 16271)

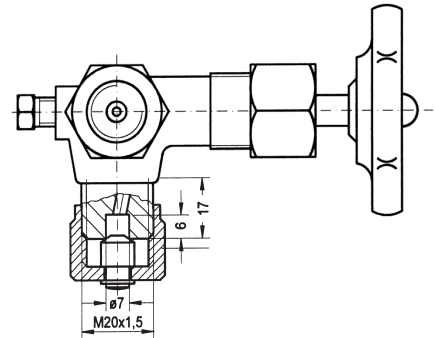

Code = P2

M20x1,5 Außengewinde mit Schutzkappe
 DIN 16287 Form D (beim Ventil DIN 16272)

*M20x1,5 male with protection-cap DIN 16287
 form D (for valve DIN 16272)*

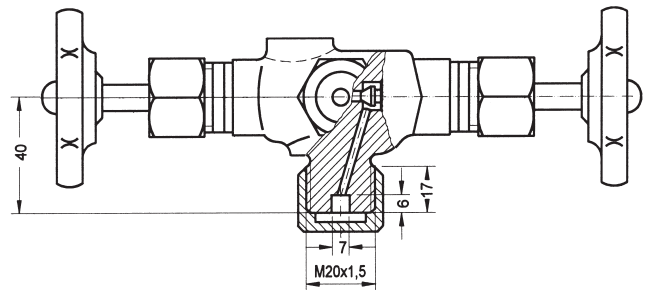

Code = P3

Schmaler rechteckiger Prüfflansch
 60mm x 25mm x 10mm
 (für Ventile DIN 16271 und 16272)

*Proof-connection with flange
 60mm x 25mm x 10mm
 (for valves DIN 16271 and 16272)*

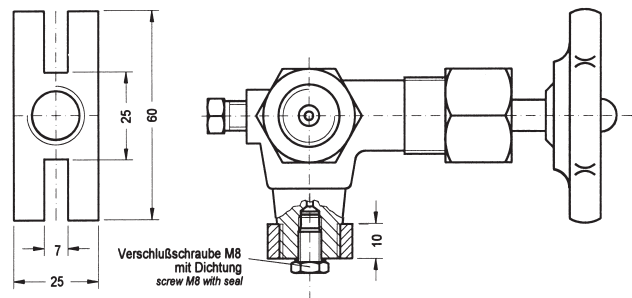

Code = P4

Runder Prüfflansch Ø 40 x 5mm
 (für Ventile DIN 16271 und 16272)

*Round proof flange Ø 40 x 5mm
 (for valves DIN 16271 and 16272)*

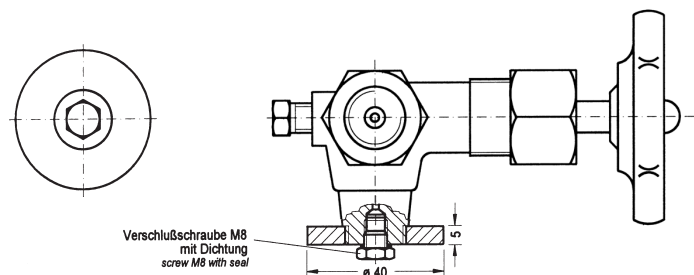

Andere Prüfanschlüsse auf Anfrage
Other proof-connections on request